

Operation Manual and Parts Book

Wessex Country FS170T and FS270T Trailed Spreaders

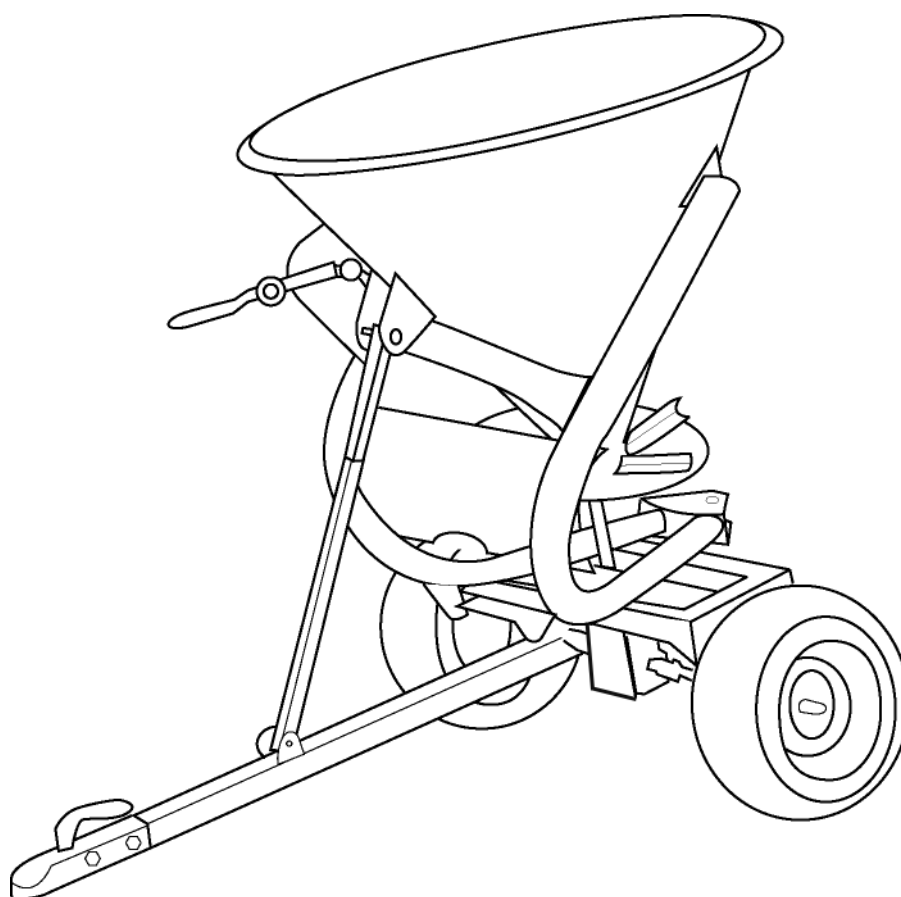

Product Code: L2033

CONTENTS

Welcome to your new Wessex Product	2
Safety Decals	3
Important Safety Warnings	4
Warranty	5
Coupling up your Trailed Spreader / Setting up your Spreader	6
Hopper loading and transport	6
Maintenance	6
Calibration	7
Adjustment of spread pattern	7
Adjusting material flow rate	8
Adjusting material flow rate - Spreading Chart	9
Specifications	9
Troubleshooting	10
Parts Illustration - Hopper Assembly	11
Parts Illustration - Trailer Frame	12
Parts Illustration - Agitator / Base Frame	13
Parts List	14, 15
Notes	16
CE Certificate	17

WELCOME TO YOUR NEW WESSEX PRODUCT

Thank you for purchasing a Wessex product. As a Wessex customer, you now number among the most important people of our business and we will endeavour to give you the best service available through our dealer network.

Please read this Manual carefully and familiarise yourself and other persons that will be using the machine with its contents, to ensure the optimum performance and working life of your machine. It is advisable that a copy of this Manual is kept in the workshop and one copy with the machine. Further copies are available through your dealer.

On delivery, your dealer should go through the workings of the machine with you, explaining the setting up procedures, all of which are contained in this manual for further reference. The Warranty Registration Form must also be completed and returned to us **within 7 days of delivery** in order to validate the Warranty.

**PLEASE READ THE FOLLOWING PAGES CAREFULLY BEFORE USING YOUR MACHINE
AND KEEP THIS MANUAL IN A SAFE PLACE.**



**THIS SAFETY SYMBOL IS TO ALERT OPERATORS OF A HAZARD
THAT MAY RESULT IN INJURY.
ALWAYS FOLLOW INSTRUCTIONS CAREFULLY**

SAFETY DECALS



- GB **ATTENTION** Description of pictograms.
 F **ATTENTION** Description des pictogrames.
 D **VORSICH** Beschreibung der piktogramme.

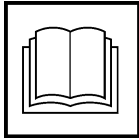

- GB Read Operating manual before use.
 F Lisez Manual D'Opération avant l'utilisation.
 D Vor der Benutzung, Betriebshandbuch lesen.

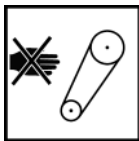

- GB Never remove guards or attempt adjustment until rotor has stopped.
 F Ne retirez jamais les gardes ou d'ajustement tentative jusqu'à ce que toutes les pièces mobiles ont été interrompus.
 D Schutzvorrichtung niemals abnehmen oder einstellung versuchen, bevore der rotor abstellt.



- GB Bystanders must be at least 20 metres from machine range of action.
 F Des spectateurs doivent s'écarter au moins 20 mètres du rayon d'action de la machine.
 D Umstehenden müssen sich mindestens 20 meter vom maschinenbetriebsraum entfernen.



- GB Protective eyewear, footwear, gloves and ear protectors must be worn.
 F Lunettes de protection, chaussures gants, protégés-oreilles doivent êtres portées.
 D Schutzbrille, schuhe, handschuhe une Gerhørschutz getragen warden muss.



- GB Stand clear. Flying objects possible.
 F S'écartez! Possibilité d'objets volants.
 D Zurückbleiben! Herumfliegende objekte möglich



- GB Do not use without pto shaft guard.
 F Ne pas utiliser sans de dispositif de sûreté de l'arbre (arbre d'entraînement).
 D Nicht benutzen ohne p.t.o. (antriebswelle) schutvorrichtung.



- GB It is the operators responsibility to ensure that the machine is compatible with the loading capacity of the towing vehicle.
 F Il est de la responsabilité des opérateurs afin de s'assurer que la machine est compatible avec la capacité de chargement du véhicule tracteur.
 D Es ist den Betreibern dafür zu sorgen, dass die Maschine mit der Belastbarkeit des Zugfahrzeugs ist.



- GB Never carry passengers on implements unless designed to do so.
 F Ne jamais transporter des passagers sur instruments sauf s'ils sont conçus pour le faire.
 D Niemals Passagiere implementiert, es sei denn ausgelegt, dies zu tun.

IMPORTANT SAFETY WARNINGS



Wessex machines are guarded for your protection, but you must always observe certain elementary precautions. Machines are potentially **dangerous** and should be used with the greatest respect and **ALL OPERATORS MUST** read this manual and be aware of all safety precautions.

1. **NEVER** attempt any adjustment whatsoever, unless the machine is **COMPLETELY** at a standstill.
2. **NEVER** attempt to clear any obstructions around the mower unless the machine is **COMPLETELY** at a standstill.
3. **NEVER** remove belt guards unless the machine is **COMPLETELY** at a standstill.
4. **NEVER** remove safety guards which are provided for your protection.
5. **NEVER** operate the machine with people behind, keep everybody (especially children and animals) at a safe distance, **minimum 20 metres**.
6. Stand well back from the machine when rotor is spinning.
7. Regularly inspect the **DISTRIBUTOR VANES AND FIXING BOLTS** to ensure that they are in tip-top condition. Replace blades **IMMEDIATELY** if any signs of fracture or excess wear becomes apparent. Serious damage, which is excluded from our warranty conditions, may result from using your mower with an unbalanced rotor. When replacing blades, always fit new mounting bolts and nuts to ensure that the rotor is balanced and running smoothly.

HEALTH AND SAFETY - Noise at Work Regulations

READING AT THE OPERATORS EAR

Wessex Country Spreaders:

Depending on conditions and material being spread, this reading may alter, it is therefore advisable for users to do their own assessment.



In compliance with the above regulations, Ear Protectors must be worn when operating machinery.

WARRANTY

Your Wessex product or equipment is warranted free from defect in workmanship or manufacture for one year from date of purchase. Any parts which appear to us to be defective, either in material or workmanship shall be replaced or repaired at no cost to the purchaser, subject to the following conditions:

1. The registration card enclosed with this booklet must be returned to us within seven days of purchase.
2. Any failure in the machine should be reported in the first instance immediately to your dealer, who will act on your behalf to resolve the matter to your satisfaction.
3. The defective parts will be returned by your dealer to us, accompanied by a full statement describing the failure and the circumstances and conditions in which the failure occurred.
4. The following are specifically excluded from our terms of warranty:
 - a) Fair wear and tear, especially to belts, brushes, blades and spinners.
 - b) Damage to blades or brushes caused through incorrect positioning of the rotor (see instructions).
 - c) Damage caused by neglect or lack of lubrication.
 - d) Damage caused by misuse or abuse.
 - e) Damage caused whilst the machine is in transit.
 - f) Damage caused to the frame of the machine by running the machine with unbalanced rotors, blades or spinners.
 - g) Damage caused to the machine by use with loose nuts, bolts, screws or any other type of fittings.
5. The warranty is for the benefit of the first user only.
6. Wessex International decisions will be final and binding.

Note:

It is recommended that every machine is inspected after one hour of operation to check that all nuts, bolts, screws or any other types of fixings are tight and any loose fixings or components should be rectified as appropriate.

Further inspections should be carried out at regular intervals thereafter.

COUPLING UP YOUR TRAILED SPREADER

- Reverse your towing vehicle up to your spreader and couple the ball hitch to the vehicle making sure that the ball hitch is locked on securely. If your spreader has a ring hitch ensure that the pin is secured with a lynch pin.

SETTING UP YOUR SPREADER

- Ensure that the spinning disk is set as level as possible with the ground. This can be adjusted on the drawbar on the trailed version, or on the top link on the tractor version. Before spreading read the full instructions of the spreader.

HOPPER LOADING & TRANSPORT

- Only load hopper when machine is hitched to the towing vehicle or coupled to the tractor.
- Do not load above the hopper rim.
- Do not stack full bags of material on top of a loaded spreader, as this will compact the material and affect the flow when spreading.
- When travelling and not spreading disengage the drive pin in the axle, this is a quick release pin at the right hand side of the gearbox.

MAINTENANCE

Regularly

- Inspect the spinner disk as an unbalance disk will cause vibration.
- Always clean thoroughly using a Pressure Washer after use, as fertiliser and salt are corrosive materials.
- Regularly grease the P.T.O. shaft, ball hitch and the axle of the trailed version.
- Never store machine with material in the hopper.
- Always store in the dry, never outside in the weather.
- Check tyre pressures regularly.

CALIBRATION

- Although we are able to produce a material spreading chart, it is by no means accurate for every fertiliser, top dressing or seed that is likely to be spread by this machine. Differing material density particle size and moisture content all affect the flow rate and spread pattern that the machine provides.
- Any material used with this machine must be dry, free flowing and stored in dry conditions to maintain its quality.
- To accurately ascertain the spread rate pattern and quality the machine should be calibrated by the use of test trays.

ADJUSTMENT OF SPREAD PATTERN

- In order to achieve a balanced spread pattern with even material application the angle of the spreader vanes must be adjusted, via the means of 4 adjustment position holes for each vane.
- The holes number 1 to 4 for each vane. All vanes must be placed in the same number hole.



- To move the spread pattern more to the left (when viewing spreader from the rear of the operating vehicle) place all the holes in hole position 1-2. To move the pattern more to the right move the vanes to hole position 3 or 4.
- When viewing spread pattern take care to ensure all persons and animals are away from the possible maximum spread pattern. Always wear safety goggles.

ADJUSTING MATERIAL FLOW RATE

- The material flow rate is adjusted by the positioning of the regulation lever. Consult the material spreading chart for the appropriate position for the regulation lever.
- For fine calibration consult the 'Calibration' section of the handbook.
- The lever positions work as follows:-

After consulting the spreading chart, according to the type of material being spread and the ground speed, move the lever "A" along the graduated scale "E", lock the lever in position with the clip "D".

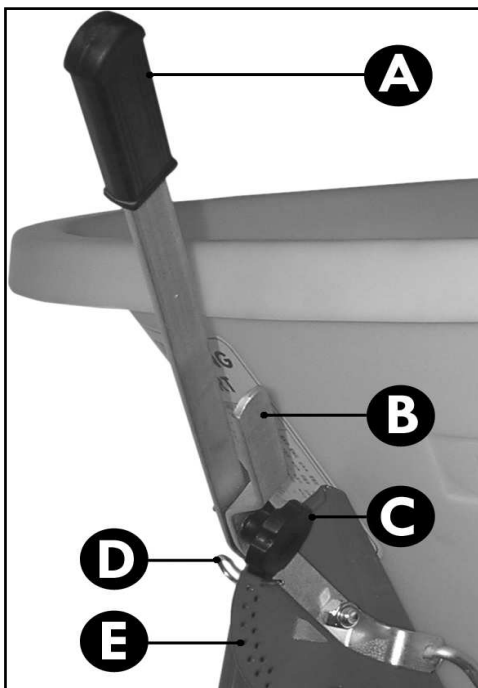

In order to spread from both sides (**ref. I**), "A" and "B" levers must be in the same position, connected by the grip handle "C".

In order to carry out the spreading only on the left hand side (**ref. II**), it is necessary to disconnect the two levers by removing the grip handle "C". Set the lever "B" in the correct position, given by the spreading chart, and bring lever "A" towards position 1 in order to close the shutter on the right hand side.

In order to spread only on to the right hand side (**ref. III**) you have to move the lever "B" up to position 1 and regulate the quantity to spread with the lever "A".

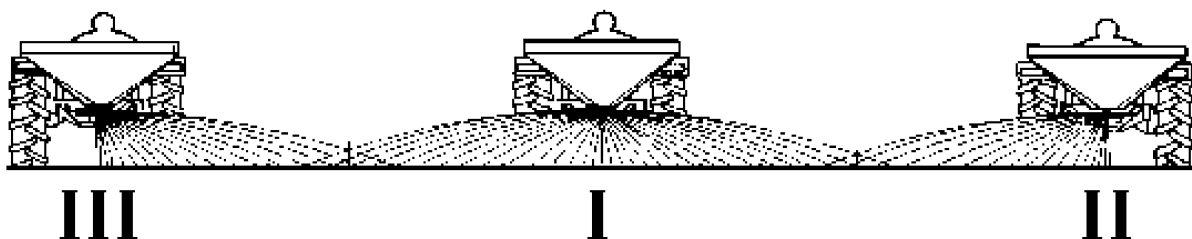

ADJUSTING MATERIAL FLOW RATE

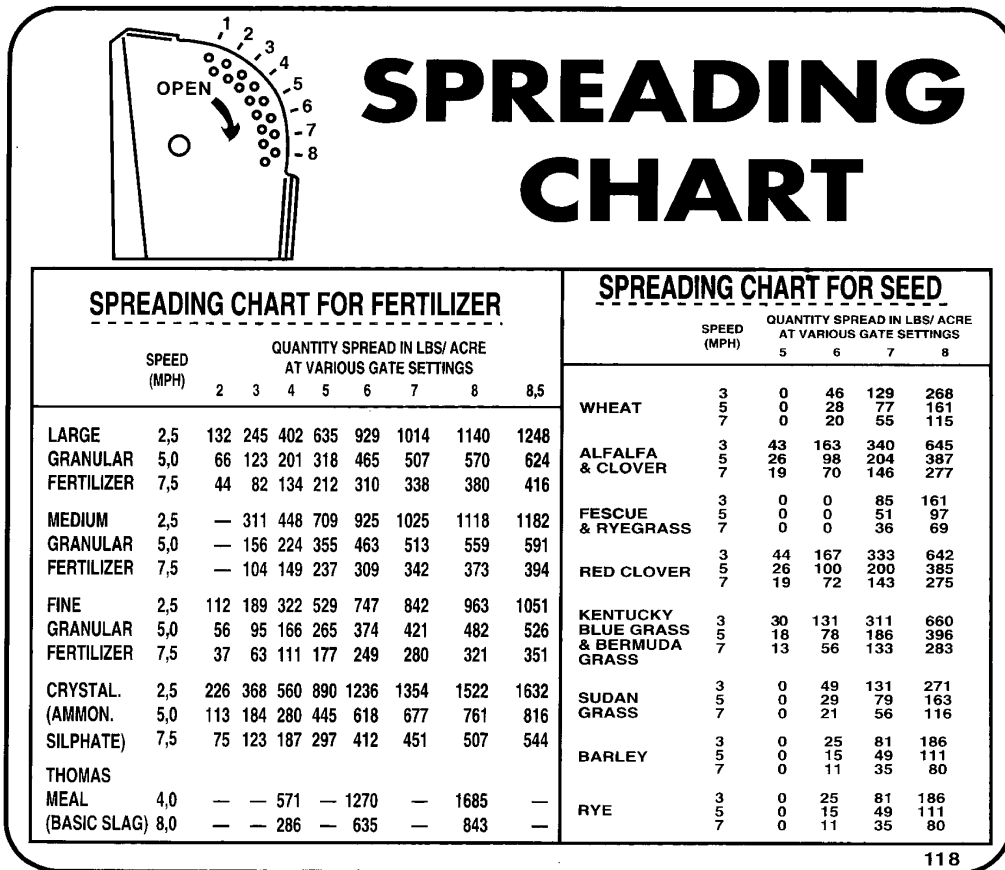

SPECIFICATIONS

	<u>FS 170T</u>	<u>FS 270T</u>
Hopper Capacity (litres)	165	260
Hopper Width (cm)	90	105
Machine Weight (kg)	80	84
Machine Width (cm)	105	105
Loading Height (cm)	130	144
Length (cm)	150	150
Ball Hitch (cm)	5	5
Tyres (type - bar)	6,5 x 3,2	6,5 x 3,2
Spreading Width (metres)	8 - 12	8 - 12
Ground Covered Per Hour	from 27 to 55 ha/h	from 7 to 15 acres/h

TROUBLE SHOOTING

FAULT	POSSIBLE CAUSE	POSSIBLE SOLUTION
Spinner not turning	<ol style="list-style-type: none"> 1. Shear bolt on axle sheared / missing 2. Ground slippery / icy 3. Agitator causing drag in dry material 	<p>Replace shear bolt</p> <p>Lower tyre pressures</p> <p>Drill axle and add second drive shear bolt</p> <p>Remove agitator when spreading dry material</p>
Spread pattern too narrow / wide	<ol style="list-style-type: none"> 1. Optional spread deflector incorrectly adjusted 2. Speed too slow / fast 	<p>Adjust deflector</p> <p>Adjust forward speed</p>
Spread pattern uneven	<ol style="list-style-type: none"> 1. Incorrect adjustment 2. Spreading disc not level 3. Disc caked in material debris 4. Travel speed in work excessive 5. Disc or disc vanes worn excessively 	<p>Consult 'how to adjust spread pattern' guide in this handbook.</p> <p>Adjust tow bar height to level</p> <p>Clean spreading disc</p> <p>Reduce speed</p> <p>Replace disc / vanes</p>
Material not flowing from machine	<ol style="list-style-type: none"> 1. Material too wet 2. Material of inconsistent quality 3. Foreign body in hopper blocking material aperture 	<p>Only use spreader with dry free flowing material</p> <p>Store material in a dry store</p> <p>Buy higher quality material</p> <p>Fit optional in hopper grid to break down large lumps</p> <p>Remove foreign body</p>

PARTS ILLUSTRATION - HOPPER ASSEMBLY

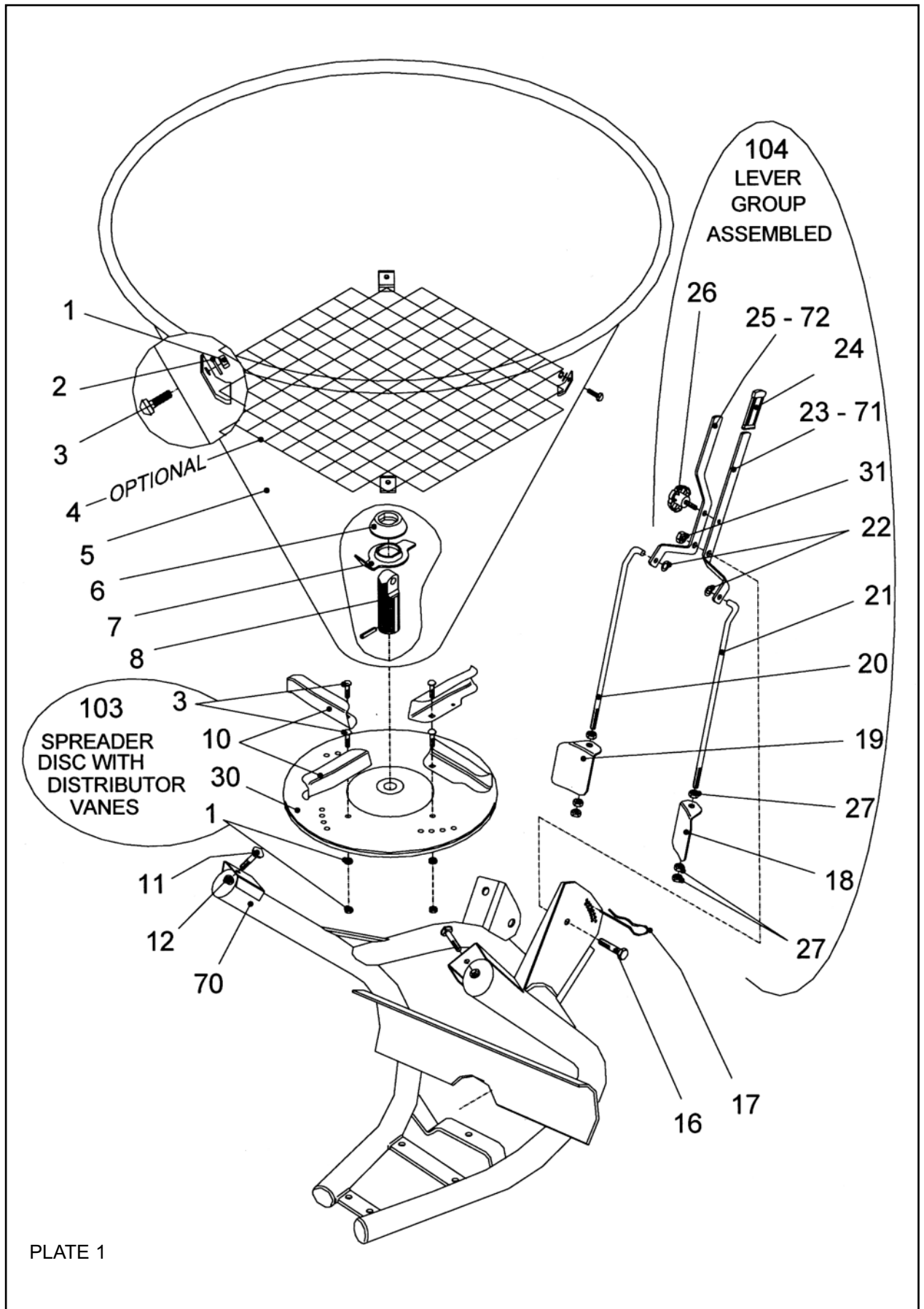

PLATE 1

PARTS ILLUSTRATION - TRAILER FRAME

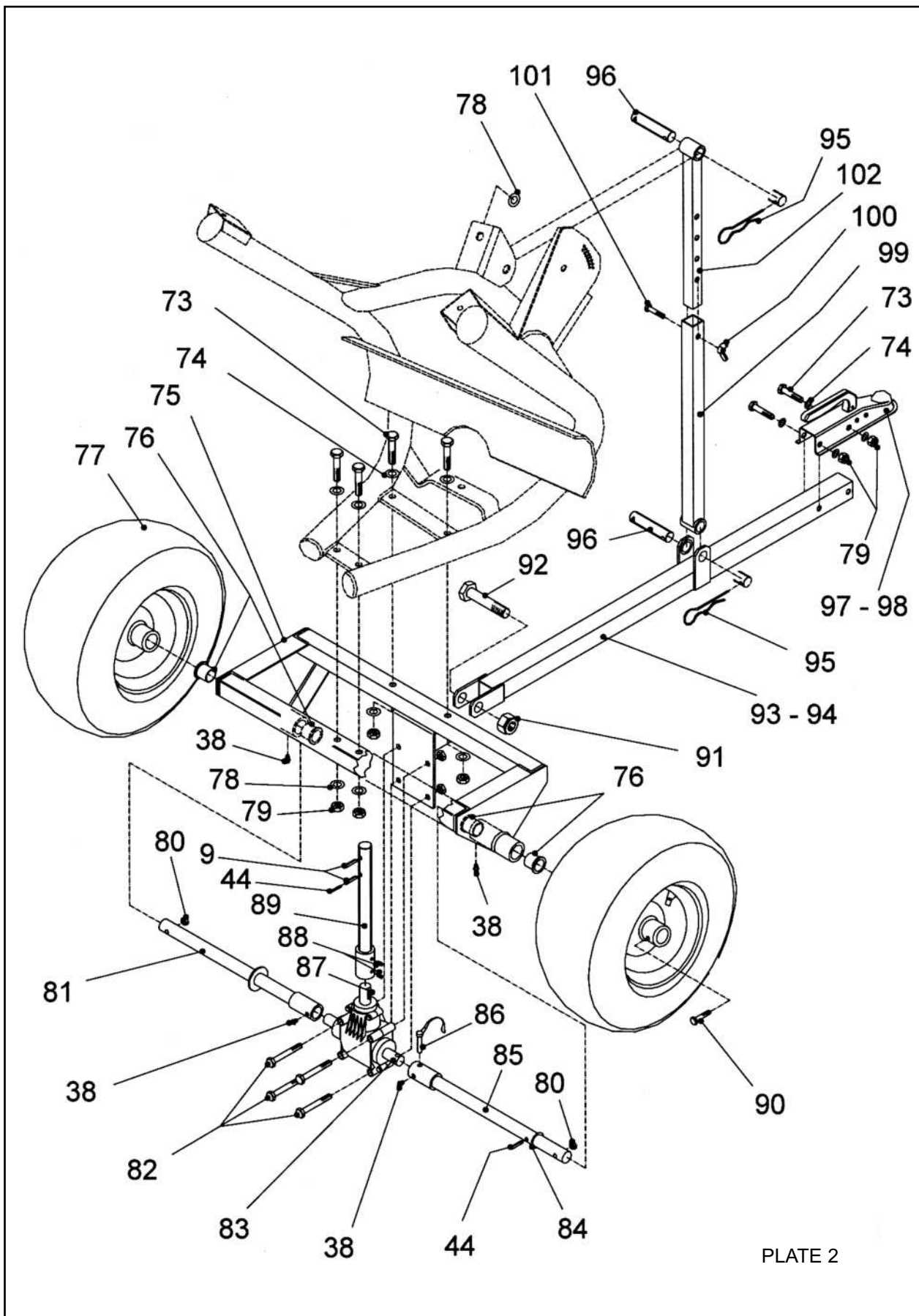

PLATE 2

PARTS ILLUSTRATIONS - AGITATOR / BASE FRAME

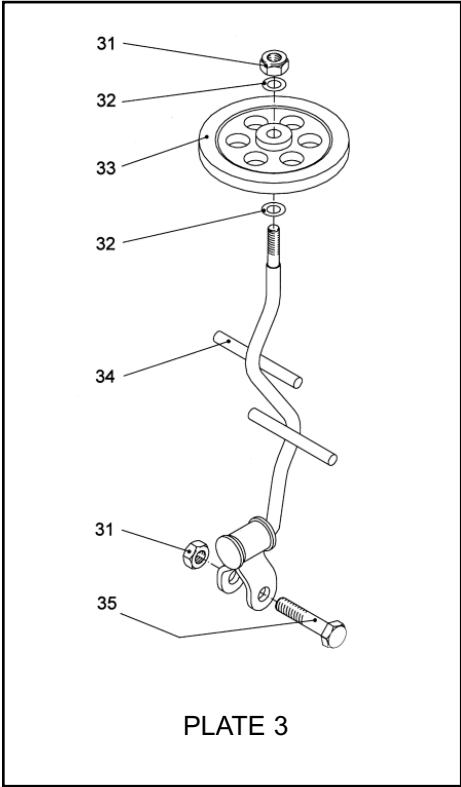

PLATE 3

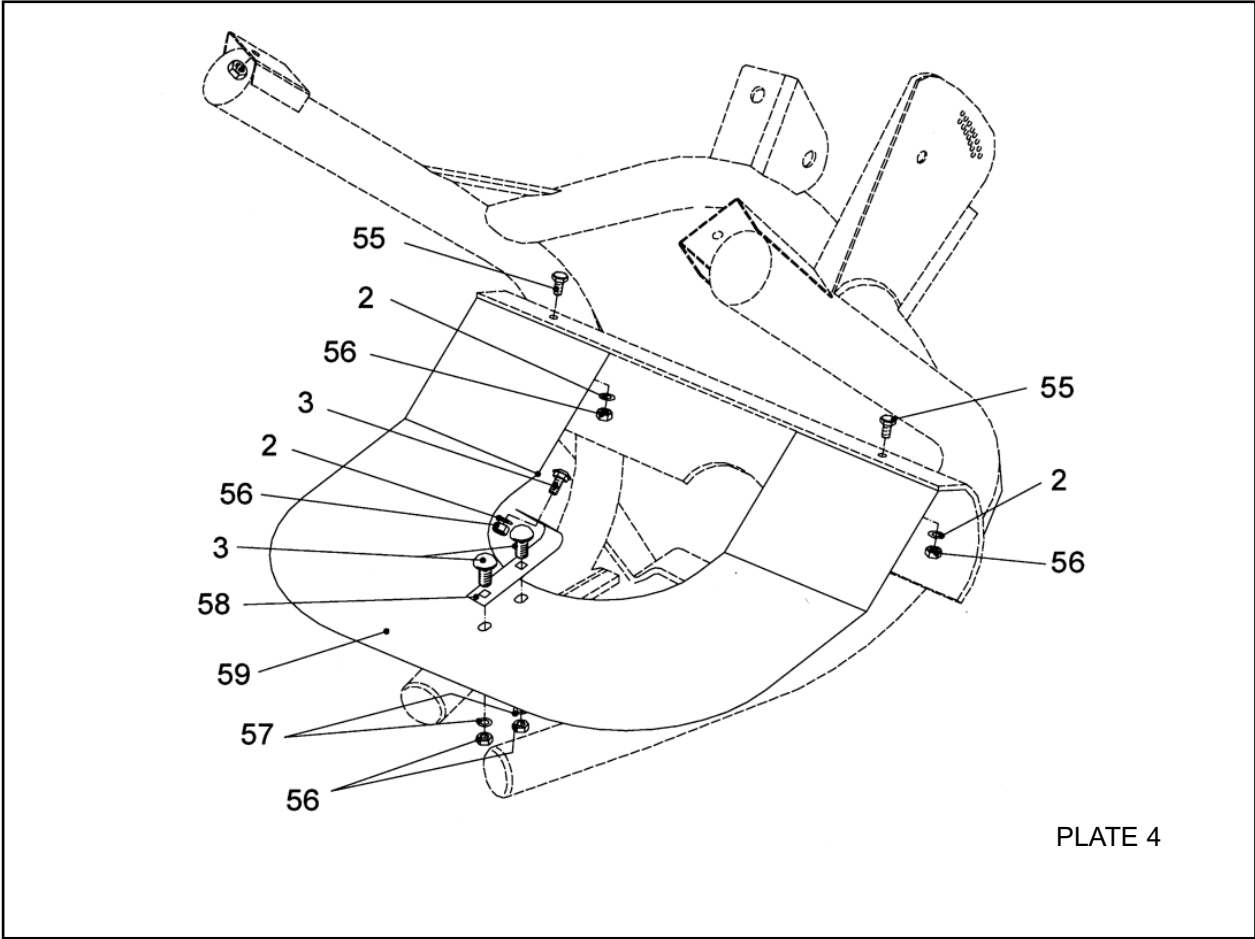

PLATE 4

PARTS LIST

Item No.	Part No.	Description	Qty
1	COS-301.012	Nut	8
2	COS-303.007	Washer	7
3	COS-300.030	Screw	11
4	COS-642.001	Protective Grill CE	1
5	COS-609.008	Hopper (170T)	1
5	COS-609.010	Hopper (270T)	1
6	COS-304.013	Rubber Ring	1
7	COS-619.002	Lower Agitator	1
8	COS-330.001	Spigot	1
9	COS-305.001	Spring Pin	2
10	COS-601.001	Distributor Vane	4
11	COS-300.023	Screw	3
12	COS-301.010	Nut	3
16	COS-300.024	Screw TE	1
17	COS-307.001	Split Pin	1
18	COS-605.004	Left Shutter	1
19	COS-605.003	Right Shutter	1
20	COS-602.001	Right Tie Rod	1
21	COS-602.002	Left Tie Rod	1
22	COS-303.009	Flat Washer	2
23	COS-604.002	Left Lever Short Version	1
24	COS-304.008	Rubber Grip	1
25	COS-604.001	Right Lever Short Version	1
26	COS-302.003	Lever Lock Knob	1
27	COS-301.014	Nut	6
30	COS-610.003	Spreader Disc Without Vanes	1
30	COS-610.013	Stainless Steel Disc Without Vanes	1
31	COS-301.008	Self Locking Nut	1
38	COS-306.002	Grease Nipple	4
44	COS-305.003	Spring Pin	2
55	COS-300.029	Screw	2
56	COS-301.012	Nut	5
57	COS-303.013	Washer	2
58	COS-606.009	Support Bracket	1
59	COS-606.010	Sheet Guard	1
70	COS-613-026	FTP Frame	1
71	COS-604.005	Right Lever Long Version	1
72	COS-604.006	Left Lever Long Version	1
73	COS-300.020	Screw	6
74	COS-303.015	Washer	8
75	COS-613.025	FTP Support Frame	1

PARTS LIST

Item No.	Part No.	Description	Qty
76	COS-325.024	Smooth Bearing With Flange	4
77	COS-620.079	Tyre	2
78	COS-303.025	Washer	5
79	COS-301.013	Self Locking Nut	10
80	COS-301.001	Self Locking Nut	2
81	COS-620.082	Right Axle	1
82	COS-300.018	Screw	4
83	COS-322.008	Gearbox	1
84	COS-303.035	Washer	1
85	COS-620.083	Left Axle	1
86	COS-302.006	Pin	1
87	COS-326.003	Key	1
88	COS-305.015	Dowel	2
89	COS-323.013	Output Shaft With Bushing	1
90	COS-300.027	Scew	2
91	COS-301.006	Self Locking	1
92	COS-300.021	Screw	1
93	COS-613.030	Tow Tube For 1" ⁷ / ₈ Hook	1
94	COS-613.031	Tow Tube For 2" Hook	1
95	COS-305.008	Spring Pin R 3	2
96	COS-633.003	Pivot Pin	1
97	WX-13080	Tow Eye	1
98	WX-2356	Tow Hitch	1
99	COS-606.061	Outer Tube Level Stop With Bushing	1
100	COS-301.005	Tongue Nut	1
101	COS-300.019	Screw	1
102	COS-606.060	Inner Tube Level Stop With Bushing	1
103	COS-610.001	Spreader Disc With Vanes	1
103	COS-610.014	Stainless Steel Disc With Vanes	1
104	COS-618-006	Lever Group Assembled RH & LH Short Versions	1
104	COS-618.013	Lever Group Assembled RH & LH Long Versions	1
	COS-619.004	Complete Agitator	1

NOTES



Certificate of CE Conformity

Machine Model:

FS170T, FS270T

Description:

Spreader

*I hereby certify that the machine detailed hereon
conforms to:*

**European Directives 2008/42/EC
Supply of Machinery Regulations 2008
As amended 91/368EEC – 93/44EEC – 93/68EEC**

Signed:

A handwritten signature in black ink, appearing to be 'R. J. ...', is written over a dotted line that extends to the right.

Quality Manager

Date:

October 2011

Wessex International

Charlton House, Caxton Place, East Portway Industrial Estate, Andover, Hampshire SP10 3QN
Telephone: 01264 345870 Fax: 01264 345 880

www.wessexintl.com



Wessex International
Charlton House, Caxton Close, East Portway Industrial Estate, Andover Hampshire. SP10 3QN
Telephone: 01264 345870 Fax 01264 345880
e-mail: sales@wessexintl.com

www.wessexintl.com
