

## Operation Manual and Parts Book

Wessex Country Log Splitter LS-100  
Hydraulically Powered, Tractor Mounted.

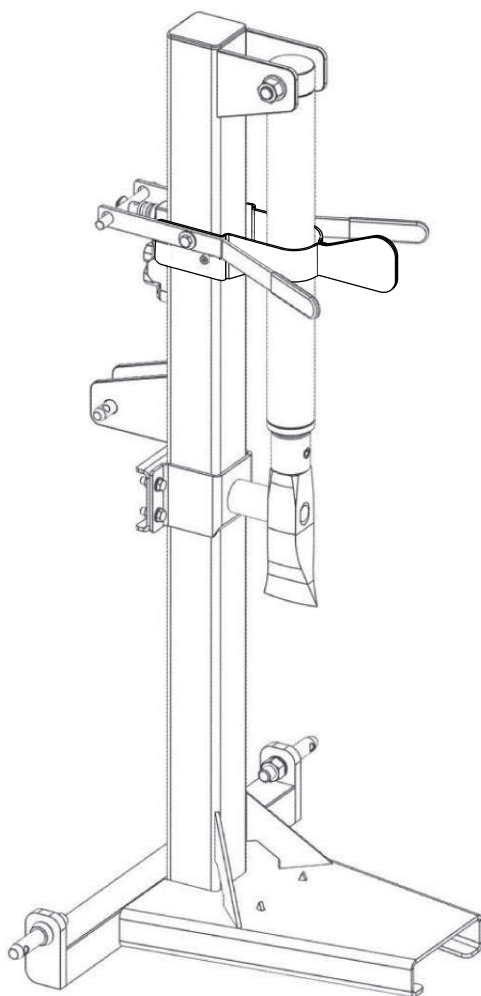

---

Product Code: L2056



**CONTENTS**

---

Welcome to your new Wessex Product .....2

Safety Decals .....3

Important Safety Warnings .....4

Warranty .....5

Connecting to the Tractor .....6

Operation .....6

Maintenance .....7

Part Illustration - Log Splitter .....8

Parts List - Log Splitter .....9

Safety Training Induction .....10

CE Certificate .....11

## WELCOME TO YOUR NEW WESSEX PRODUCT

---

Thank you for purchasing a Wessex product. As a Wessex customer, you now number among the most important people of our business and we will endeavour to give you the best service available through our dealer network.

Please read this Manual carefully and familiarise yourself and other persons that will be using the machine with its contents, to ensure the optimum performance and working life of your machine. It is advisable that a copy of this Manual is kept in the workshop and one copy with the machine. Further copies are available through your dealer.

On delivery, your dealer should go through the workings of the machine with you, explaining the setting up procedures, all of which are contained in this manual for further reference. The Warranty Registration Form must also be completed and returned to us **within 7 days of delivery** in order to validate the Warranty.

**PLEASE READ THE FOLLOWING PAGES CAREFULLY BEFORE USING YOUR MACHINE  
AND KEEP THIS MANUAL IN A SAFE PLACE.**



**THIS SAFETY SYMBOL IS TO ALERT OPERATORS OF A HAZARD  
THAT MAY RESULT IN INJURY.  
ALWAYS FOLLOW INSTRUCTIONS CAREFULLY**

## SAFETY DECALS

---



- GB **ATTENTION** Description of pictograms.  
F **ATTENTION** Description des pictogrames.  
D **VORSICH** Beschreibung der piktogramme.



- GB Read Operating manual before use.  
F Lisez Manual D'Opération avant l'utilisation.  
D Vor der Benutzung, Betriebshandbuch lesen.



- GB Ear defenders must be worn.  
F Défenseurs des oreilles doivent être portés.  
D Gehörschutz getragen werden.



- GB Eye Protection must be worn.  
F Protection des yeux doit être porté.  
D Augenschutz getragen werden.



- GB Foot Protection must be worn.  
F Protection des pieds doit être porté.  
D Fußschutz müssen getragen werden.



- GB Protective Gloves must be worn.  
F Gants de protection doivent être portés.  
D Schutzhandschuhe müssen getragen werden.

## IMPORTANT SAFETY WARNINGS

---



Log Splitters by their very nature are potentially **dangerous machines** and should be used with the greatest of respect.

Ensure that **ALL** operators are aware of the following:-

1. The machine must always be used by **one** Operator only at any one time.
2. **NEVER** attempt any adjustment whatsoever, unless the machine and **ALL its moving parts are completely at a standstill and the machine is disabled by either stopping the operating tractors engine or disconnecting the hydraulic couplers.**
3. The machine must always be used with the two hand control. **Never tamper with this device.** Two hands must be used to operate the controls of the down strokes of the ram at all times.
4. **NEVER** wear loose, unbuttoned clothing when operating the Log Splitter. Always tie long hair back.
5. **NEVER** enter Hands or Feet into the area of the Splitting Blade while in operation.
6. Always split logs in the direction of the grain. **NEVER** split across the grain.
7. **NEVER** operate with spectators within 3.0 metres.
8. Observe all safety warning decals.
9. **ALWAYS** wear appropriate safety clothing when operating the Splitter as detailed on Page 3 of the Handbook.
10. When transporting your LS-100 keep your speed down especially when travelling over rough surfaces. Travelling at high speeds will cause damage to the mounting system and valve block and is not covered by the Wessex Warranty.

## WARRANTY

---

Your Wessex product or equipment is warranted free from defect in workmanship or manufacture for one year from date of purchase. Any parts which appear to us to be defective, either in material or workmanship shall be replaced or repaired at no cost to the purchaser, subject to the following conditions:

1. The registration card enclosed with this booklet must be returned to us within seven days of purchase. Alternatively if you prefer, you may register your product via our Website.  
<http://www.wessexintl.com/warranty-registration>
2. Any failure in the machine should be reported in the first instance immediately to your dealer, who will act on your behalf to resolve the matter to your satisfaction.
3. The defective parts will be returned by your dealer to us, accompanied by a full statement describing the failure and the circumstances and conditions in which the failure occurred.
4. The following are specifically excluded from our terms of warranty:
  - a) Fair wear and tear, especially to seals and blades.
  - b) Damage caused by neglect.
  - c) Damage caused by misuse or abuse, including impact damage to blades.
  - d) Damage caused whilst the machine is in transit.
  - e) Damage caused to the machine by use with loose nuts, bolts, screws or any other type of fittings.
5. The warranty is for the benefit of the first user only.
6. Wessex International decisions will be final and binding.

**Note:**

**It is recommended that every machine is inspected after one hour of operation to check that all nuts, bolts, screws or any other types of fixings are tight and any loose fixings or components should be rectified as appropriate.**

**Further inspections should be carried out at regular intervals thereafter.**

## CONNECTING TO THE TRACTOR

---

- The LS-100 can be operated free standing or connect to your tractors 3 point linkage.
- Never allow anyone to stand between the tractor and the Log Splitter.
- If fully connecting to your tractor, reverse the tractor up to the Log Splitter, first connect the bottom link arms of the tractor and secure with lynch pins.
- Connect the tractor top link to the machine.
- Tighten the check chains on the tractor link arms, to stop the sideways movement.
- Plug the two hydraulic pipes into the tractor. The pressure pipe is marked with a 'P' on the valve block, and the returning pipe is marked with a 'T' on the valve block.
- Set the tractor hydraulics to constant pumping before operating.

## OPERATION

---

- Park the Tractor in the desired location activating the parking brake.
- Adjust your tractors 3 point linkage so that the machine sits level on the ground.
- Position the tractor's throttle at the suitable RPM so that the tractors hydraulics provides sufficient power to operate the log splitter.
- Place a log on the table ready for splitting, ensure that the log is firmly placed before activating the splitter.
- To activate the splitter operate both control handles at the same time, to retract the splitter move both handles in the opposite plane.

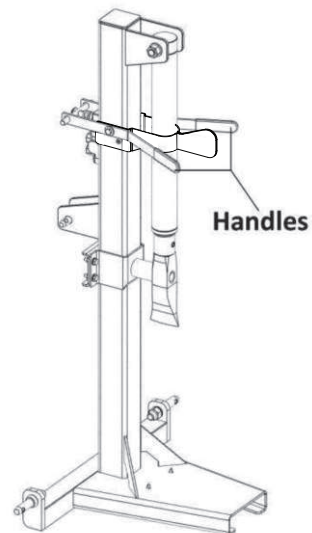



## MAINTENANCE

---

To keep your Log Splitter in excellent working condition we recommend that you follow this maintenance programme:-

### REGULARLY:-

- Check all fastening sets after 8 hours work.
- After long periods of operation the splitting wedge may need sharpening.
- Periodically lightly grease the main slide beam to avoid wear.
- Inspect all hydraulic hoses and fittings for leaks and damage.

Only use genuine Wessex parts in the event of replacing worn parts. This will ensure the continued safe use of your Log Splitter and the validity of your warranty.

### HEALTH AND SAFETY - Noise at Work Regulations

#### READING AT THE OPERATORS EAR

**Wessex LS Log Splitter: Approximately 96 D.B.A**

Depending on conditions and material being cut, this reading may alter, it is therefore advisable for users to do their own assessment.



In compliance with the above regulations, Ear Protectors must be worn when operating machinery.

# PARTS ILLUSTRATION - LOG SPLITTER

PLATE 1

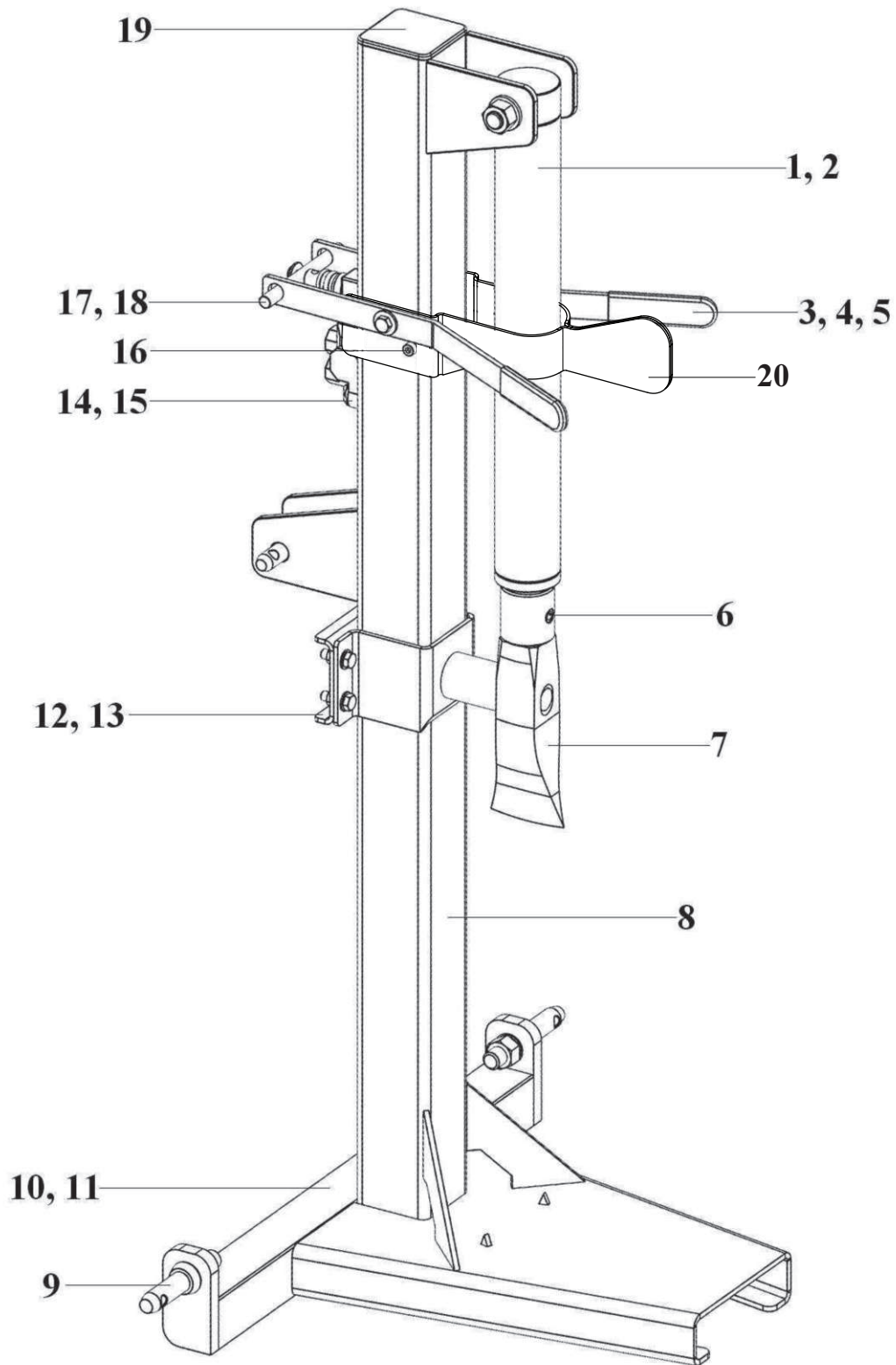

## PARTS LIST - LOG SPLITTER

<b>Item No.</b>	<b>Part No.</b>	<b>Description</b>	<b>QTY</b>
1	WX-15356	Hydraulic Cylinder	1
2	WX-34501	Hydraulic Cylinder Fastening Set	1
3	WX-7176	Control Lever	2
4	WX-20780	Lever Grip	2
5	WX-30301	Lever Fastening Set	1
6	WX-4822	Roll Pin	1
7	WX-9358	Axe Head Assembly	1
8	WX-12379	Main Frame	1
9	WX-0226	Link Pin	2
10	WX-9458	Linkage Bar	1
11	WX-3503	Linkage Bar Fastening Set	4
12	WX-7276	Clamp Plate	1
13	WX-30401	Clamp Plate Fastening Set	4
14	WX-15456	Valve Block	1
15	WX-34001	Valve Block Fastening Set	2
16	WX-30501	Control Stops	2
17	WX-20980	Valve Bar	1
18	WX-30501	Valve Bar Fastening Set	1
19	WX-20880	Blanking Plug	1
20	WX-19477	Safety Bracket	1
Not Shown	WX-15556	Complete Hose Kit	1





## *Certificate of CE Conformity*

Machine Model:

LS100

Description:

LOG SPLITTER

*I hereby certify that the machine detailed hereon  
conforms to:*

**European Directives 2008/42/EC  
Supply of Machinery Regulations 2008  
As amended 91/368EEC – 93/44EEC – 93/68EEC  
HSE AIS 33**

Signed:

A handwritten signature in black ink, consisting of a large, stylized 'R' followed by a horizontal line and a flourish.

.....  
Quality Manager

Date:

24/11/2010

### **Wessex International**

Charlton House, Caxton Place, East Portway Industrial Estate, Andover, Hampshire SP10 3QN  
Telephone: 01264 345870 Fax: 01264 345 880

[www.wessexintl.com](http://www.wessexintl.com)



**Wessex International**  
Charlton House, Caxton Close, East Portway Industrial Estate, Andover Hampshire. SP10 3QN  
Telephone: 01264 345870 Fax 01264 345880  
e-mail: [sales@wessexintl.com](mailto:sales@wessexintl.com)

[www.wessexintl.com](http://www.wessexintl.com)